

display racking

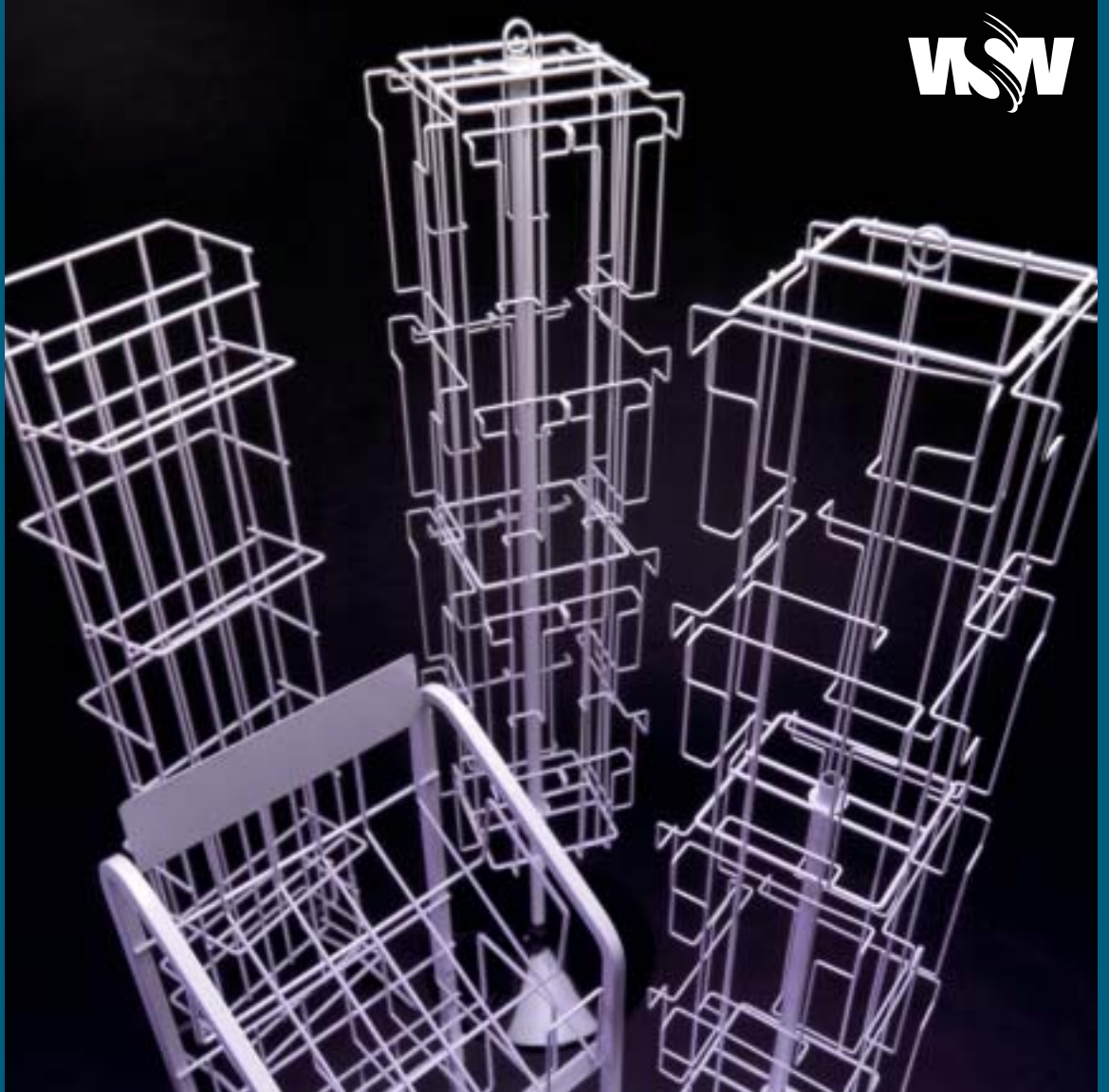

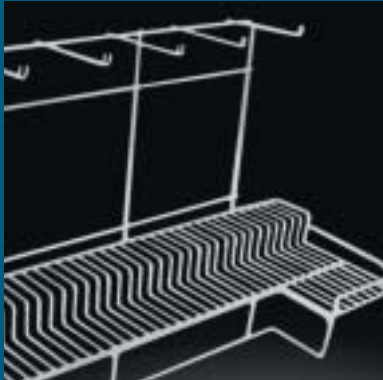

display racking

When it comes to retail selling, presentation is what counts. Display Racking and Point of Purchase Displays designed by Western Spring and Wire are now front and centre in some of the biggest retail chains across Canada.

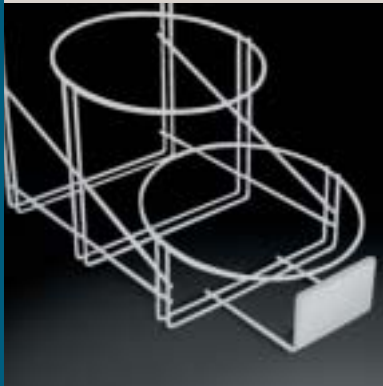

custom designed display systems

Our designers work hand-in-hand with retail and commercial clients to develop merchandising displays that maximize product appeal to generate sales. With our high quality standards, you can depend on all our products surviving the daily wear and tear of the world of shopping.

The next time you need creative support in developing an effective merchandising program, think of Western Spring and Wire.

We will provide you with the widest possible choice of display racking systems; custom-designed to showcase products and maximize sales.



display racks product list

Literature Racks

Greeting Card Racks

Newspaper Racks

Refrigeration and
Oven Racks

Snack Racks

Wire Grids and Accessories

Carpet Display Racks

Point of Purchase
Merchandising

Bun and Bread Baskets

Baskets and Bins for
Novelty Items and Gifts

If you can think it, we can
design and produce it.

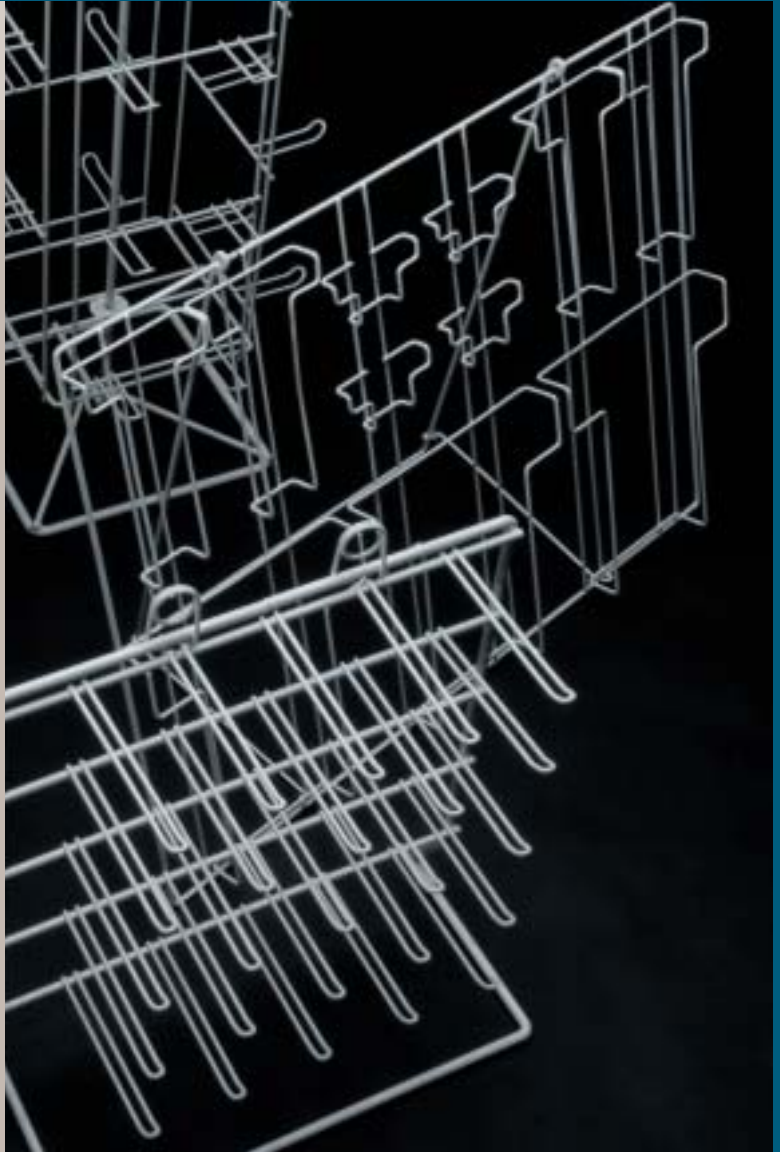

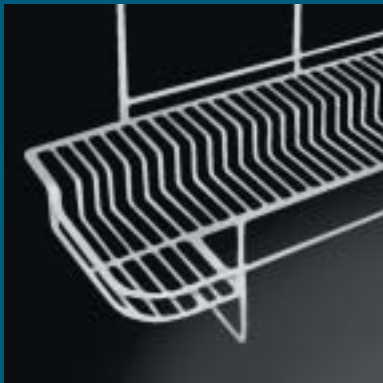

display systems

So if you have a special promotion planned, or would like to discuss new merchandising techniques, just contact your nearest Western Spring and Wire location. We are ready when you are!



our commitment to excellence

That quality originates with our CAD specialists who work closely with you to develop precise specifications for each job. Next, we take care to select the best choice of raw materials, and high grade finishes including plating, polishing and powder coating. Then, it is over to our manufacturing and quality control specialists who work as a team to ensure your order conforms to the most stringent standards.

That level of assurance we give to all our customers. It is what has made us an industry leader.

Western Spring and Wire... you can depend on our commitment to excellence.



western spring & wire

ONTARIO

156 Sugar Maple Road,
P.O. Box 500,
St. George, Ontario
N0E 1N0
tel 519-448-4588
fax 519-448-4590
toll free 1-800-667-4733

ALBERTA

Ste. 204, 1135-64th Avenue S.E.,
Calgary, Alberta
T2H 2J7
tel 403-640-9400
fax 403-640-9477
toll free 1-800-661-7937

MANITOBA

55 Keith Road,
Winnipeg, Manitoba
R3H 0H7
tel 204-694-7128
fax 204-694-7129
toll free 1-800-661-7654

NOVA SCOTIA

Unit 115A, 11 Morris Drive,
Dartmouth, Nova Scotia
B3B 1M2
tel 902-469-2669
fax 902-469-2659
toll free 1-888-412-4424

e-mail: info@wsw.ca
www.wsw.ca